

Selection diagram

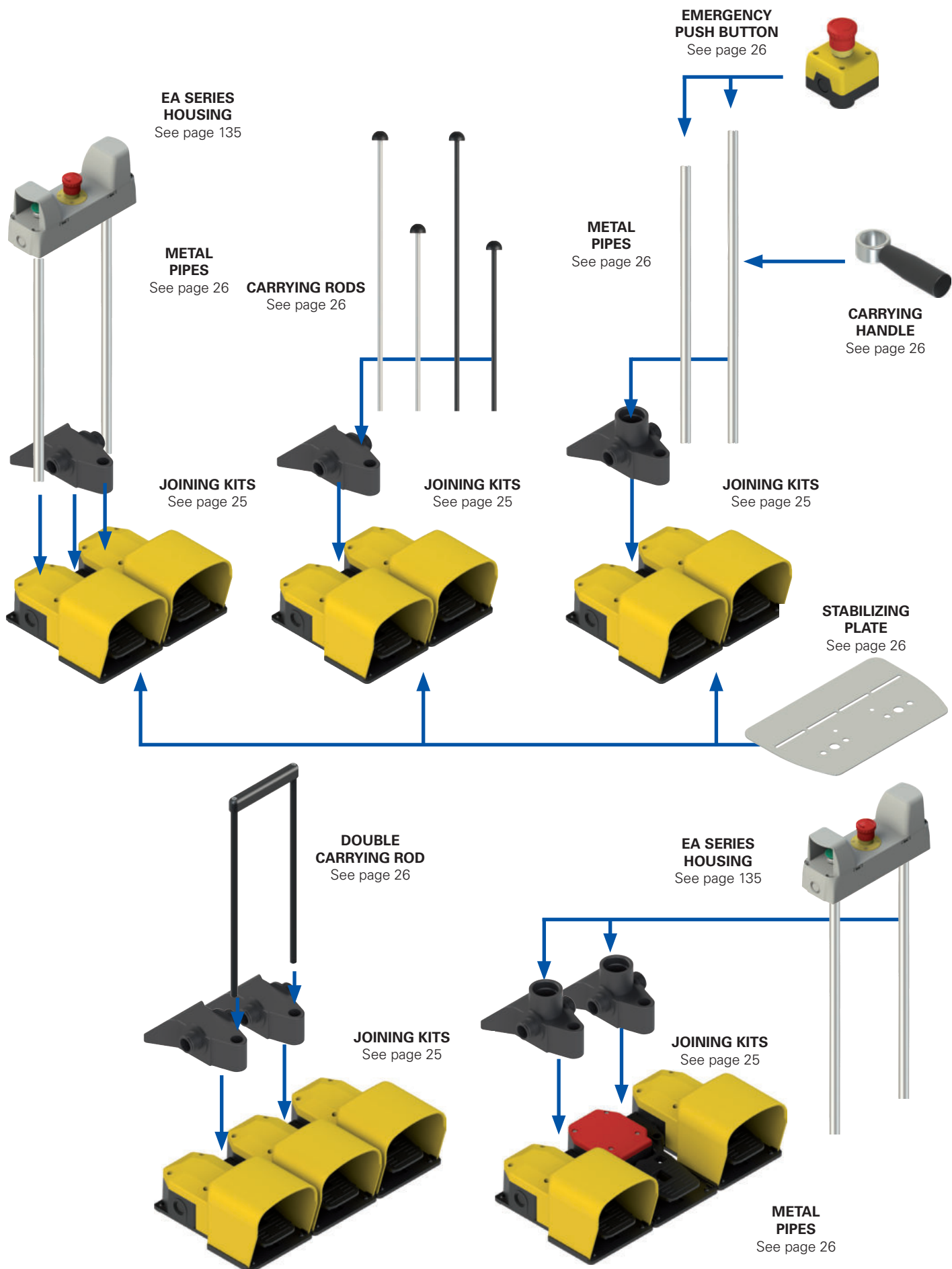

● Product options
→ Sold separately as accessory

Combinations of existing double foot switches

If you wish to purchase modular foot switches already assembled or with a single order code, please contact our sales department. Before contacting our offices, please look at the following table where some already assigned multiple foot switch combinations are listed.

Code	Left foot switch	Joining element	Right foot switch	Additional sets
PC 2-101	PX 10110-M2	VF KIT20	PX 10110-M2	VF KIT21
PC 2-102	PX 10111-M2	VF KIT20	PX 10111-M2	
PC 2-103	PX 20110-M2	VF KIT20	PX 10210-M2	VF KIT21
PC 2-104	PX 20110-M2	VF KIT20	PX 10110-M2	VF KIT21
PC 2-105	PX 10110-M2	VF KIT20	PX 20110-M2	VF KIT21
PC 2-106	PX 10120-M2	VF KIT20	PX 10110-M2	VF KIT21
PC 2-107	PX 10310-M2	VF KIT20	PX 10310-M2	VF KIT21
PC 2-108	PX 10410-M2	VF KIT20	PX 10410-M2	VF KIT21
PC 2-109	PX 10210-M2	VF KIT20	PX 10210-M2	VF KIT21
PC 2-110	PX 10301-M2	VF KIT20	PX 10301-M2	
PC 2-111	PX 10100-M2	VF KIT20	PX 10100-M2	
PC 2-112	PX 10111-M2	VF KIT20	PX 10111-M2	VF KIT21
PC 2-113	PX 10120-M2	VF KIT20	PX 10120-M2	VF KIT21
PC 2-114	PX 10411-M2	VF KIT20	PX 10411-M2	VF KIT21
PC 2-115	PX 10211-M2	VF KIT20	PX 10201-M2	
PC 2-116	PX 10211-M2	VF KIT20	PX 10211-M2	VF KIT21
PC 2-117	PX 10100-M2	VF KIT20	PX 10210-M2	VF KIT21
PC 2-118	PA 20100-M2	VF KIT20	PX 10110-M2	VF KIT21
PC 2-119	PA 20101-M2	VF KIT20	PX 10111-M2	VF KIT21
PC 2-120	PA 20300-M2	VF KIT20	PX 10310-M2	VF KIT21
PC 2-121	PA 20120-M2	VF KIT20	PX 10110-M2	VF KIT21
PC 2-122	PA 20121-M2	VF KIT20	PX 10111-M2	VF KIT21
PC 2-123	PA 20200-M2	VF KIT20	PX 10810-M2	VF KIT21
PC 2-124	PA 20100-M2	VF KIT20	PX 10210-M2	VF KIT21
PC 2-125	PA 20100-M2	VF KIT20	PX 10100-M2	VF KIT21
PC 2-126	PA 20100-M2	VF KIT20	PA 20100-M2	VF KIT21
PC 2-127	PA 20400-M2	VF KIT20	PA 20400-M2	VF KIT21
PC 2-128	PX 10110-M2	VF KIT30	PX 10110-M2	
PC 2-129	PA 20100-M2	VF KIT30	PX 10110-M2	
PC 2-130	PX 10111-M2	VF KIT30	PX 10111-M2	
PC 2-131	PX 10110-BM2	VF KIT20	PX 10110-BM2	
PC 2-132	PX 10111-M2	VF KIT30	PX 10111-M2	VF KIT29+ VF KIT32+VF KIT50
PC 2-133	PX 20210-M2	VF KIT20	PX 20210-M2	
PC 2-134	PX 20410-M2	VF KIT20	PX 20410-M2	
PC 2-35	PX 20211-M2	VF KIT20	PX 20211-M2	
PC 2-137	PX 10421-M2	VF KIT20	PX 10401-M2	
PC 2-138	PX 10210-M2	VF KIT20	PX 20210-M2	VF KIT21
PC 2-139	PX 40220-M2	VF KIT20	PX 40200-M2	
PC 2-40	PA 20100-M2	VF KIT20	PX 10110-M2	VF KIT22
PC 2-141	PX 10110-M2	VF KIT20	PA 20100-M2	
PC 2-142	PX 10111-M2	VF KIT30	PX 10111-M2	VF KIT31+ VF KIT32
PC 2-143	PX 10100-M2	VF KIT30	PX 10210-M2	VF KIT31+ VF KIT33
PC 2-144	PX 10810-M2	VF KIT30	PX 10110-M2	VF KIT31+ VF KIT32
PC 2-145	PX 40100-M2	VF KIT30	PX 40100-M2	VF KIT31+ VF KIT33
PC 2-146	PA 20100-M2	VF KIT30	PX 10110-M2	VF KIT31+ VF KIT36
PC 2-147	PX 10110-M2	VF KIT30	PX 12040-M2	VF KIT31+ VF KIT34
PC 2-148	PX 10110-M2	VF KIT20	PX 10110-M2	VF KIT21 + VF KIT61
PC 2-149	PX 10111-M2	VF KIT30	PX 10111-M2	VF KIT29+ VF KIT32+VF KIT50+ VF KIT61
PC 2-150	PX 40310-M2	VF KIT30	PA 20300-M2	VF KIT29+ VF KIT32

Combinations of existing triple foot switches

Code	Left foot switch	Joining element	Central foot switch	Joining element	Right foot switch	Additional sets
PC 3-11	PX 10110-M2	VF KIT20	PA 20100-M2	VF KIT20	PX 10110-M2	
PC 3-12	PX 10100-M2	VF KIT20	PX 10100-M2	VF KIT20	PX 10100-M2	
PC 3-13	PX 10110-M2	VF KIT20	PA 20100-M2	VF KIT20	PX 10110-M2	VF KIT40
PC 3-14	PX 10110-M2	VF KIT30	PX 10110-M2	VF KIT30	PX 10110-M2	2x VF KIT31 + 2x VF KIT18

Note:

VF KIT21, 22, 26, 29, 31, 32, 33, 34, 35, 40, 50 sets are not supplied assembled because, in order to be wired, kits should be first disassembled in any case.

How to combine the modular foot switches

All single foot switches (see page 17) are provided with knock-out side openings, designed for inserting the threaded ends of the joining elements. By tightening the threaded nuts of the joining elements a tight cable feed-through for electrical cables is created between the foot switches. In addition to this, with the supplied screws, the joining elements allow the definitive mechanical locking and the stabilization of two or more foot switches as a single object.

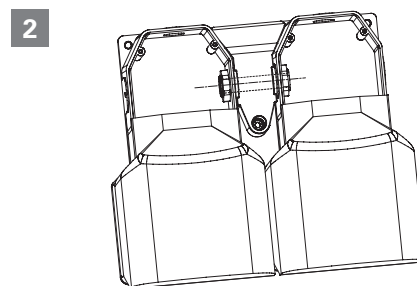
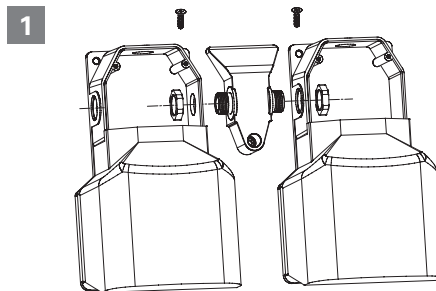
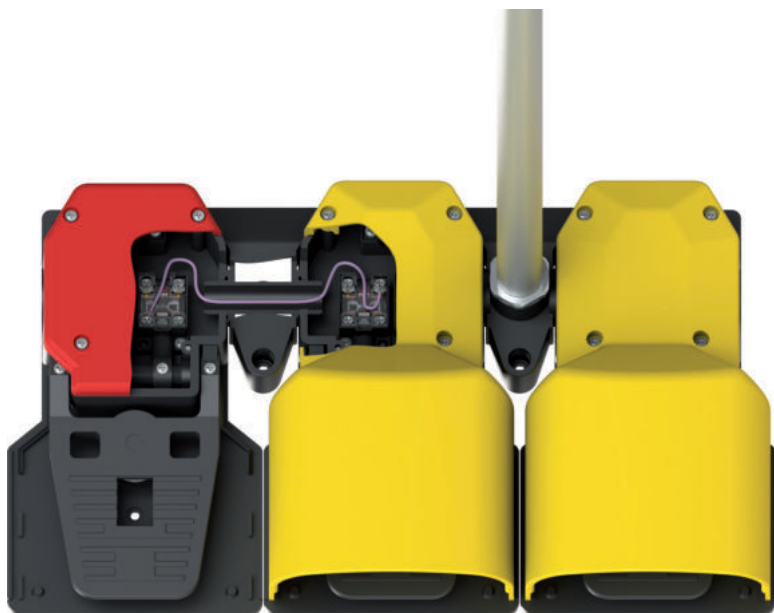

Besides the possibility of joining from two to four single foot switches, the joining elements make it possible to apply a metal tube that enables the electrical connection between the foot contacts and the contacts of an emergency push button, connected to the same tube, preserving thus an IP65 protection degree.

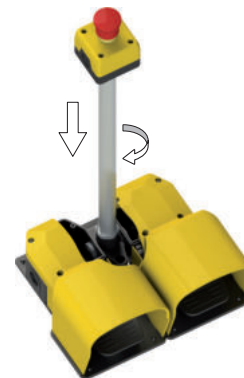
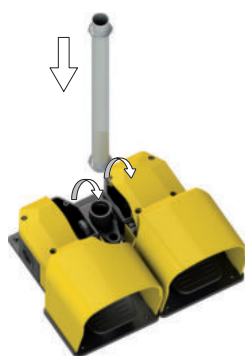

Joining elements for modular foot switches

Article	Description
VF KIT20	Joining element

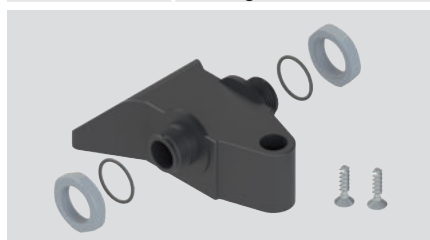

Joining element for technopolymer pedals with hole for carrying rod, with nuts, seals and self-tapping screws for the fixing of the two single pedals. Protection degree IP65.

Article	Description
VF KIT30	Joining element



Joining kit for technopolymer pedals with M25x1.5 threaded hole (for VF KIT31 or VF KIT29) with nuts, gaskets and self-tapping screws for joining two single pedals. Protection degree IP65.

Auxiliary elements for modular foot switches

Article	Description
VF KIT21	Carrying rod set, L=400 mm
VF KIT22	Carrying rod set, L=660 mm

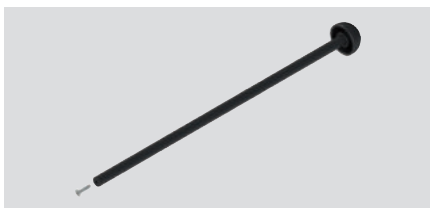

Plastic carrying rod set (can be connected to VF KIT20) with self-tapping screw for rod fixing.

Article	Description
VF KIT40	Double carrying rod set, L=400 mm
VF KIT41	Double carrying rod set, L=600 mm

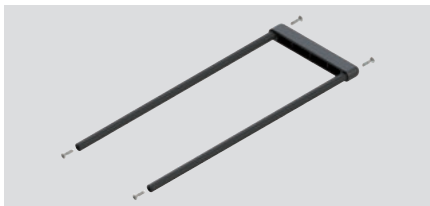

Double carrying rod kit with handle and self-tapping screws for fixing, to be combined with two VF KIT20.

Article	Description
VF KIT18	Metal nut



Metal nut M25x1.5 to combine with VF KIT31 or VF KIT29 if housings of the EA series are used.
Packs of 10 pcs.

Article	Description
VF KIT50	Carrying handle



Carrying handle kit for metal tube Ø 25 mm (VF KIT31 - VF KIT29).

Article	Description
VF KIT61	Metal stabilizing plate

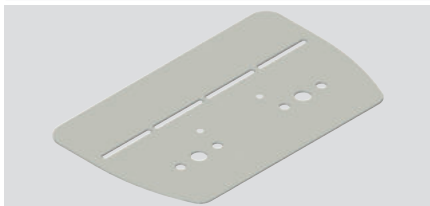

Metal stabilizing plate for double pedals.

Note: VF KIT21, 22, 25, 26, 29, 31, 32, 33, 34, 35, 40, 41, 50 sets can be supplied already assembled.

Article	Description
AC 1270	Closed protection, yellow technopolymer
AC 1027	Closed protection, red technopolymer
AC 1271	Closed protection, grey technopolymer
AC 1275	Closed protection, black technopolymer
AC 1276	Closed protection, blue technopolymer

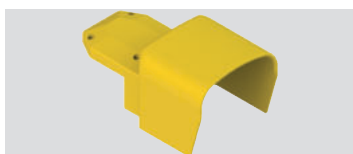

Ideal as a spare part, in case of damage to the one provided with the foot switch.

Article	Description
VF KIT25	Metal carrying rod set, L=400 mm
VF KIT26	Metal carrying rod set, L=660 mm



Metal carrying rod set (can be connected to VF KIT20) with self-tapping screw for rod fixing.

Article	Description
VF KIT31	Ø 25 mm metal tube set, L=660 mm
VF KIT29	Ø 25 mm metal tube set, L=740 mm

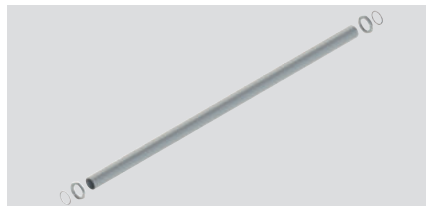

Ø 25 mm metal tube set with M25x1.5 threaded ends (for VF KIT32, VF KIT33, VF KIT34, VF KIT35) with metal nuts and gaskets.
Protection degree IP65.

Article	Description
VF KIT32	Emergency stop button kit, 1NC
VF KIT33	Emergency stop button kit, 1NC+1NO
VF KIT34	Emergency stop button kit, 2NC
VF KIT35	Housing set for Ø 22 mm buttons

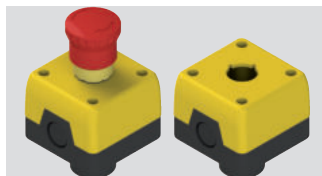

Emergency stop button kit, rotary release, compliant with EN 60947-5-1 and EN ISO 13850, to combine with VF KIT31 or VF KIT29.
Protection degree IP65.

Additional contacts on page 87.

Article	Description
VF KIT60	Metal stabilizing plate

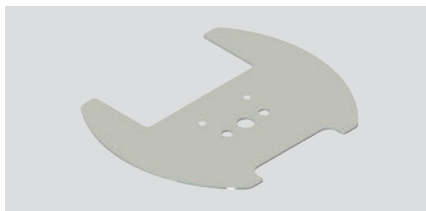

Metal stabilizing plate for single pedal.

Article	Description
VF KIT71	Yellow single metal protection

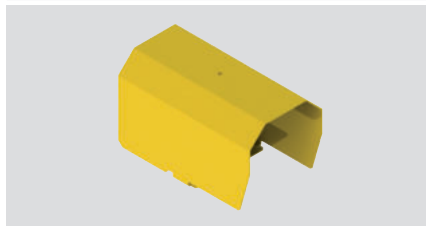

Additional metal protections for single PA series foot switches. In heavy-duty work environments, increased dimensions for safety shoes. Not applicable with VF KIT60.

Article	Description
VF KIT81	Yellow double metal protection

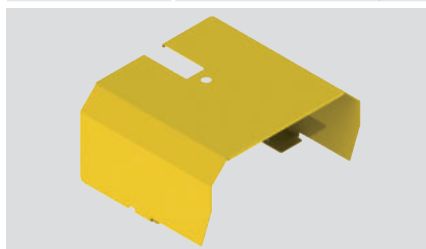

Additional metal protections for PC series modular foot switches. In heavy-duty work environments, increased dimensions for safety shoes. Not applicable with VF KIT61.

Combination examples

Double foot switches with joining device, metal tube and 1NC emergency stop button

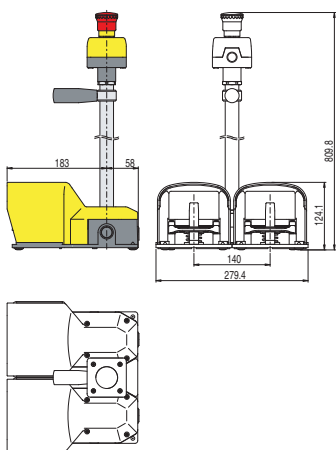

Ordering example:

2x PX 10110-M2	VF KIT30
VF KIT50	VF KIT31
VF KIT32	

Triple foot switches with two joining devices and double carrying rod

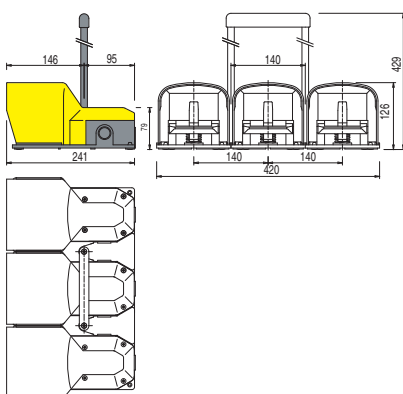

Ordering example:

3x PX 10110-M2	2x VF KIT20
VF KIT40	

Double foot switch with joining device, two metal tubes, stabilizing plate and EA series housing



EA SERIES HOUSING
See page 135

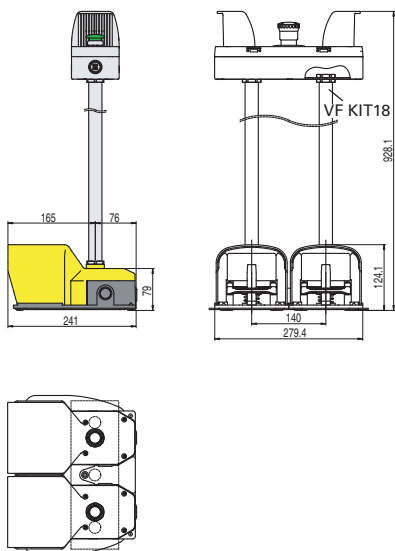

Ordering example:

2x PX 10110-BM2	VF KIT20
2x VF KIT29	2x VF KIT18
VF KIT61	EA AC37041

Triple foot switches with two joining devices, two metal tubes and EA series housing

EA SERIES HOUSING
See page 135

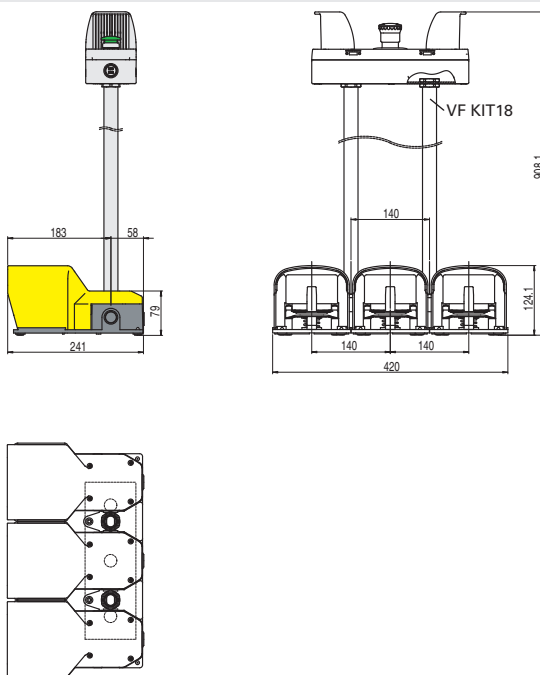

Ordering example:

3x PX 10110-M2	2x VF KIT30
2x VF KIT29	2x VF KIT18
EA AC37041	

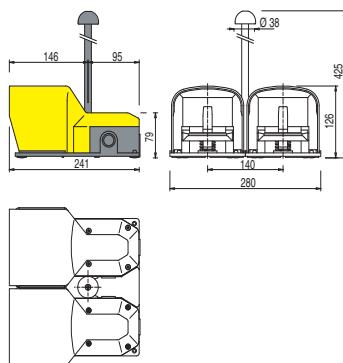
Double foot switches with joining device and carrying rod

Ordering example:

2x PX 10110-M2	VF KIT20
VF KIT21	

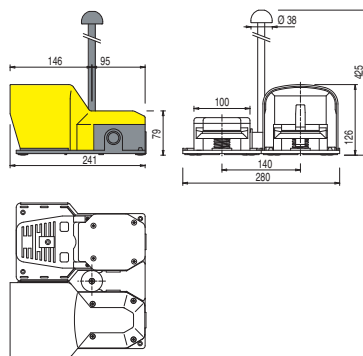
Double foot switches (available with or without pedal actuator protection) with joining device and carrying rod

Ordering example:

PX 10110-M2	PA 20100-M2
VF KIT20	VF KIT21

All values in the drawings are in mm